

ENTRAINEMENT COUTEAU SERIE 5000

POULIE MOTEUR LONGUE COTE GAUCHE

T 5000

TL 5000

2008

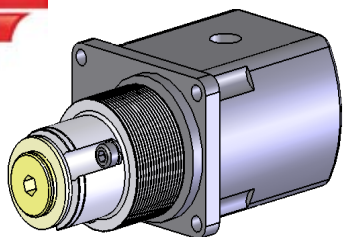

NRV0022A-Y

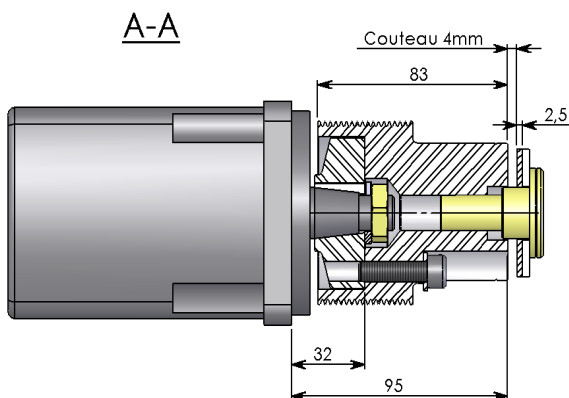
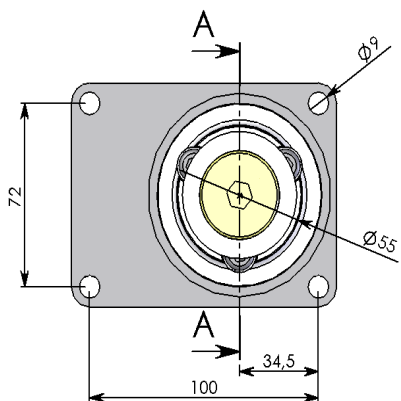
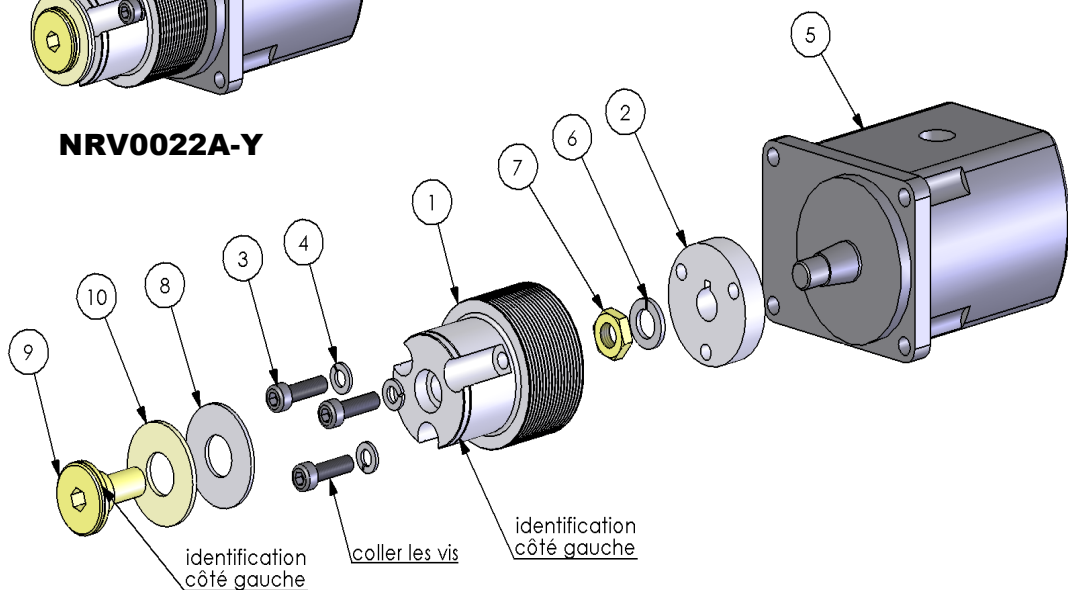

NOMENCLATURE

Rep.	Qté	Code	Référence	Désignation
1	1	2206307	RV006200A-Y	POULIE MOTEUR LONGUE M14 A GAUCHE
2	1	2206065	RV000200E	MOYEU MOTEUR
3	3	40176	124351	VIS CHC 08 x 30 FT AZI
4	3	37473	124205	RONDELLE Gr 08 AZI
5	1	2205921	-	MOTEUR HYDRAULIQUE 8cc CONIQUE CONTRE PALIER
6	1	37458	124216	Rondelle Gr M14 AZI
7	1	L00729	3070	ECROU H B 14 AZI
8	1	2207036	2897	RONDELLE RESSORT D20 AZI
9	1	2206075	RV002300C-Y	VIS SECURITE M14 EPAULEE pas à gauche
10	1	47729	1663	RONDELLE M20 AZI TYPE L

Date: 18 Juillet 2009

REF: 9901.105

ind.
A

Ferrand

+33 4 68 47 77 90

ferrand-sas@orange.fr

FERRAND, ZI Carrefour de BEZONS
11620 VILLEMOSTAUSSOU