

ENTRAINEMENT COUTEAU SERIE 5000

POULIE COURTE COTE GAUCHE

T 5000

TL 5000

2007

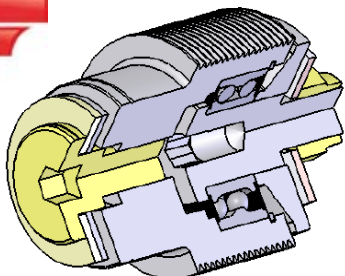

NRV0006D-Y
Tecnomat: 2207032

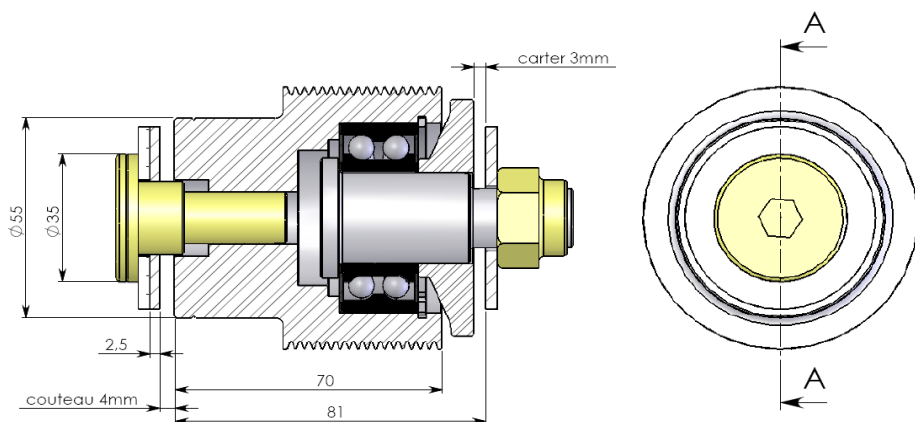
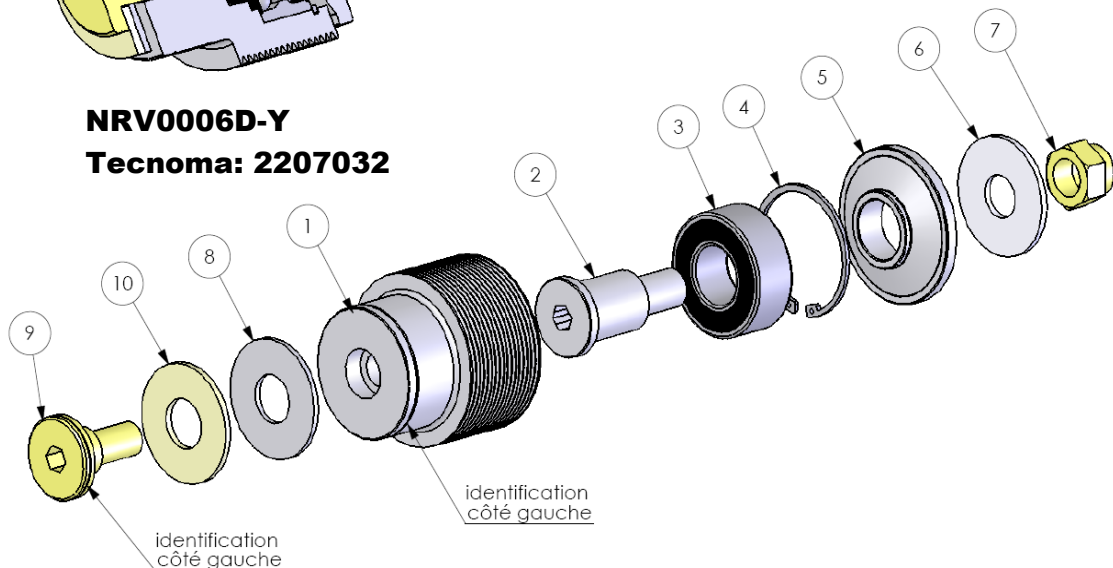

NOMENCLATURE

Rep.	Qté	Code	Référence	Désignation
1	1	2206071	RV000300D-Y	POULIE COURTE M14 A GAUCHE
2	1	2206068	RV004600A	VIS SPECIALE M16 EPAULEE POUR ROULEMENT
3	1	2206247	2813	ROULEMENT CONTACT OBLIQUE 3205-2RS
4	1	89190	2066	CIRCLIPS INTERIEUR D52
5	1	2206073	RV000500D	PIED ENTRAINEMENT COUTEAU
6	1		-	RONDELLE M 16 AZI TYPE LL
7	1	46479	124193	ECROU HM 16 AZI 8.8 FREIN
8	1	2207036	2897	RONDELLE RESSORT D20 AZI
9	1	2206075	RV002300C-Y	VIS SECURITE M14 EPAULEE pas à gauche
10	1	47729	1663	RONDELLE M20 AZI TYPE L

Date: 05 Mars 2009

REF: 9901.109 | ind. D



+33 4 68 47 77 90
 ferrand-sas@orange.fr
 FERRAND, ZI Carrefour de BEZONS
 11620 VILLEMOSTAUSSOU