

DISQUE DE BUTTAGE LISSE Ø250 et Ø300
DOUBLE ORIENTATION
HDI220T (2026436)

2008 →

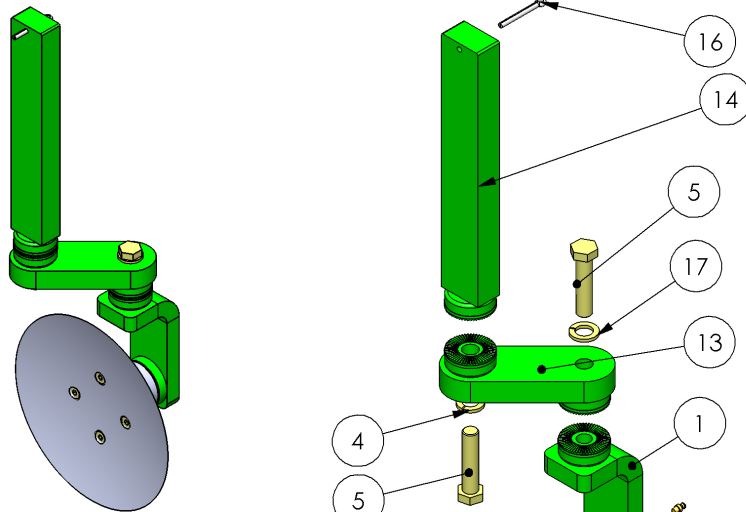

MONTAGE DES ROULEMENTS A ROULEAUX:
 BLOQUER L'ECROU M16 PUIS DESSERRER 1/4 DE
 TOUR. METTRE COLLE SUR FILETAGE..

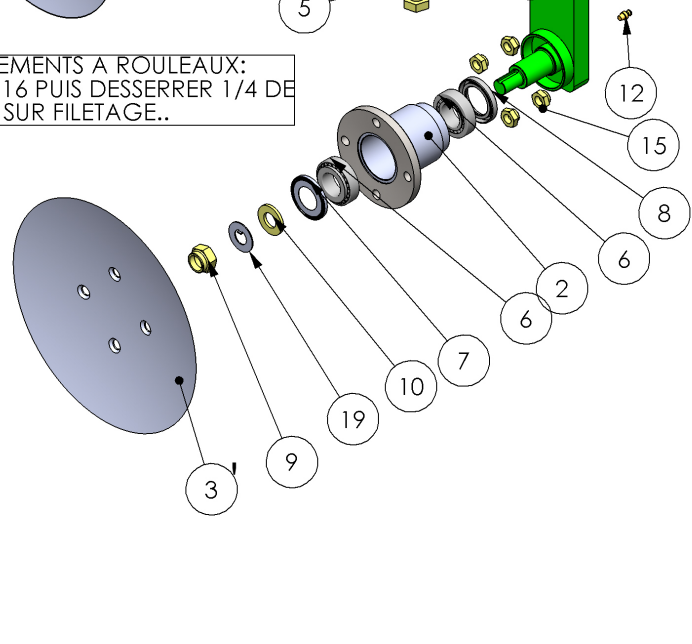

NIN0062-lisse

11



NOMENCLATURE

Rep.	Qté	Code TECNOMA	Référence	Désignation
1	1	2208204	IN031800	Support pivot double orientation rd crantée Ø50
1'	1		IN031800	Support pivot double orientation rd crantée Ø65 Z48
2	1	2208205	IN020900	Palier
3'	1	2208217	IN034200	Disque de buttage ø250
3''	1	2208218	IN021000	Disque de buttage ø300
4	1		A7R*11*16*2	Rondelle Gr M16 AZI
5	2		A7V*02*16*070*2	Vis HM 16 X 70 FP AZI
6	2	2208206	A8RO*KB*25*47*15	Roulement a rouleaux 25*47*15
7	1	2208207	4015	NILOS 32005X AV
8	1	2208208	A61*SPI*30*47*7	Joint SPI 30*47*7
9	1		A7E*02*16*2	Ecrou HM 16 AZI 8.8 frein
10	1		A7R*01*16*2	Rondelle M 16 AZI
11	4		A7*21*10*05*2	Vis F HC M 10 X 25 FT AZI 8.8
12	1		301	Graisseur M6
13	1	2208209	IN034400	Bras orientable EA110 rondelle crantée Ø50
13'	1		IN034400	Bras orientable EA110 rondelle crantée Ø65 Z48
14	1	2208210	IN031600	Montant 50*30 rondelle crantée Ø50
14'	1		IN031600	Montant 50*30 rondelle crantée Ø65 Z48
15	4		A7E*02*10*2	Ecrou HM 10 AZI 8.8 frein
16	1		4084	Goupille fendue 5x50
17	1		A7R*11*18*2	Rondelle Gr M18 AZI
18'				
18''				
19	1	2208213	A7-0027	Rondelle frein d'ecrou a ergot int M16 zingue
20				
21				
22				
23				
24				
25				
26				
27				
28				
29				
30				
31				
32				
33				
34				
35				
36				
37				
38				
39				
40				
41				
42				
43				
44				
45				

REF PL: 99029045

ind.
A

Date: 24/03/2014



+33 4 68 47 77 90
 ferrand-sas@orange.fr
 FERRAND, 21 Carrefour de BEZONS
 11620 VILLEMOUSTAUSSOU